

Condensing unit
Voltage Code : FZ

CAJN2428ZBR-FZ

Low Temp. Commercial (BP)

220 - 240V 1~ 50 Hz

R452A / R404A / R448A / R449A

CAJN2428ZBR-FZ

Conditions	Frequency	Nominal Cooling Capacity		Sound Power ISO3745 / ISO 3743-1
		Watts	BTU/h	
EN13215 / R452A	50 Hz	283	965	57 dBA
EN13215 / R404A	50 Hz	315	1075	57 dBA
EN13215 / R448A	50 Hz	228	776	57 dBA
EN13215 / R449A	50 Hz	228	776	57 dBA

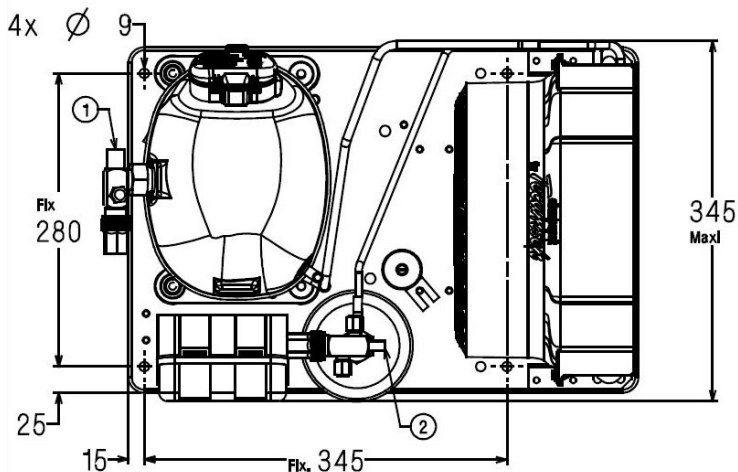
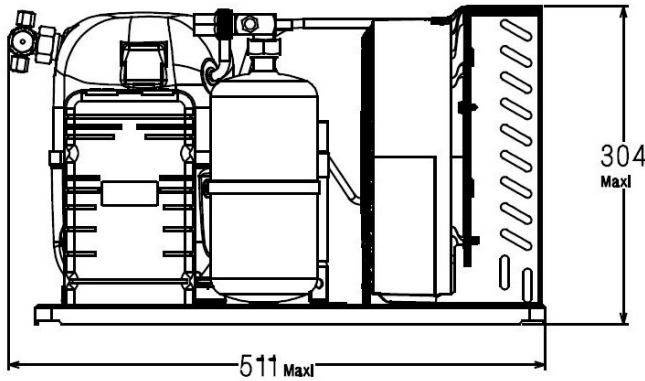

* EN13215 : T°Ambient 32.0°C / T°Evap. -35.0°C / T°Return gas temp.. 20.0°C
T°Subcooling. 3.0K

Net Weight (Kg)	30.0
Expansion device	Expansion_Valve
Air Flow (m³/h)	550
Compo Data Sheet	124CS-FZ
Elec Comp Type	CSIR
Current (Amp)	
Load Rated Amp	3.4
Max Cont Current	5.3
Lock Rotor Amp	22
Fan	
Speed (rpm)	1200
Power (W)	16.0
Diameter (mm)	250
Protection	Overload
IP Level	IP54
Condenser	250/2050
Liquid Receiver	
Capacity (L)	1.5
Maximum Pressure (Bars)	32.0
Suction Line	
Suction Type	Vanne Orientable
For Tubing Out Diam	12.7 (1/2")
Suction Connection Type	Brased
Liquid Line	
Liquid Line Type	Vanne Orientable
For Tubing Out Diam	6.35 (1/4")
Liquid Connecton Type	Brased
Connection Type	VR
Fan Guard	maille < à 8mm

Note : Tecumseh reserves the right to change information contained in this document without notification.



Tecumseh

CAJN2428ZBR-FZ	Tension FZ : 220 - 240V 1~ 50 Hz
-----------------------	---

Les performances sont données dans les conditions EN13215 :	Gaz aspirés :	20.0 °C
Condition Dew	Sous refroidissement :	3.0 K
The performance data are in EN13215 conditions :	Return gas :	20.0 °C
Dew Condition	Subcooling :	3.0 K

© 2018 Tecumseh Products Company
All rights reserved

50 Hz R452A

N°5904

5 T ambience	6 T évaporation	(°C)	-40	-35	-30	-25	-20	-15	-10
25	1 P frigorifique	(Watt)	241	334	444	571	715	876	1052
	2 P absorbée	(W)	314	368	431	502	584	678	784
	3 I absorbée	(A)	2.73	2.84	3.00	3.22	3.49	3.81	4.19
	4 Tc	(°C)	29.0	31.3	33.7	36.2	38.9	41.8	44.8
32	1 P frigorifique	(Watt)	198	283	383	497	627	771	930
	2 P absorbée	(W)	299	355	420	496	581	679	789
	3 I absorbée	(A)	2.69	2.82	2.99	3.22	3.51	3.84	4.22
	4 Tc	(°C)	34.9	37.1	39.4	41.9	44.5	47.3	50.2
43	1 P frigorifique	(Watt)	131	203	286	381	488	608	742
	2 P absorbée	(W)	270	327	394	473	563	665	781
	3 I absorbée	(A)	2.60	2.75	2.96	3.21	3.51	3.85	4.25
	4 Tc	(°C)	44.3	46.3	48.5	50.9	53.3	56.0	58.8

50 Hz R404A

N°5030

5 T ambience	6 T évaporation	(°C)	-40	-35	-30	-25	-20	-15	-10
25	1 P frigorifique	(Watt)	271	371	487	618	764	924	1094
	2 P absorbée	(W)	338	397	463	538	622	717	825
	3 I absorbée	(A)	2.93	3.05	3.22	3.44	3.71	4.04	4.41
	4 Tc	(°C)	31.9	34.1	36.5	39.0	41.6	44.4	47.3
32	1 P frigorifique	(Watt)	224	315	420	539	670	812	964
	2 P absorbée	(W)	326	386	454	532	621	721	834
	3 I absorbée	(A)	2.91	3.04	3.23	3.46	3.74	4.07	4.46
	4 Tc	(°C)	37.7	39.8	42.0	44.4	47.0	49.6	52.4
43	1 P frigorifique	(Watt)	152	229	316	414	522	639	764
	2 P absorbée	(W)	299	359	430	511	605	711	831
	3 I absorbée	(A)	2.86	3.01	3.21	3.46	3.76	4.10	4.50
	4 Tc	(°C)	46.8	48.7	50.8	53.0	55.4	57.9	60.5

1 = cooling capacity 2 = power input 3 = current 4 = condensing temperature 5 = ambient temperature 6 = evaporating temperature

Nota : Tecumseh se réserve le droit de modifier les informations contenues dans ce document sans préavis.

Note : Tecumseh reserves the right to change information contained in this document without notification.



Tecumseh

CAJN2428ZBR-FZ	Tension FZ : 220 - 240V 1~ 50 Hz
-----------------------	---

Les performances sont données dans les conditions EN13215 :	Gaz aspirés :	20.0 °C
Condition Dew	Sous refroidissement :	3.0 K
The performance data are in EN13215 conditions :	Return gas :	20.0 °C
Dew Condition	Subcooling :	3.0 K

© 2018 Tecumseh Products Company
All rights reserved

50 Hz R448A (*)

N°6897

5 T ambience	6 T évaporation	(°C)	-30	-25	-20	-15	-10
25	1 P frigorifique	(Watt)	376	501	646	811	997
	2 P absorbée	(W)	406	476	556	646	748
	3 I absorbée	(A)	2.84	3.06	3.33	3.64	4.00
	4 Tc	(°C)	34.1	36.6	39.4	42.3	45.3
32	1 P frigorifique	(Watt)	323	437	570	722	894
	2 P absorbée	(W)	397	471	554	648	754
	3 I absorbée	(A)	2.85	3.08	3.36	3.68	4.04
	4 Tc	(°C)	39.8	42.3	45.0	47.8	50.7
43	1 P frigorifique	(Watt)		342	456	589	
	2 P absorbée	(W)		450	537	637	
	3 I absorbée	(A)		3.08	3.37	3.71	
	4 Tc	(°C)		51.3	53.8	56.4	

50 Hz R449A (*)

N°5434

5 T ambience	6 T évaporation	(°C)	-30	-25	-20	-15	-10
25	1 P frigorifique	(Watt)	376	501	646	811	997
	2 P absorbée	(W)	406	476	556	646	748
	3 I absorbée	(A)	2.84	3.06	3.33	3.64	4.00
	4 Tc	(°C)	34.1	36.6	39.4	42.2	45.3
32	1 P frigorifique	(Watt)	324	437	570	722	894
	2 P absorbée	(W)	397	471	554	648	754
	3 I absorbée	(A)	2.85	3.08	3.36	3.68	4.04
	4 Tc	(°C)	39.8	42.3	44.9	47.7	50.6
43	1 P frigorifique	(Watt)		342	456	589	
	2 P absorbée	(W)		450	537	637	
	3 I absorbée	(A)		3.08	3.37	3.71	
	4 Tc	(°C)		51.3	53.8	56.4	

1 = cooling capacity 2 = power input 3 = current 4 = condensing temperature 5 = ambient temperature 6 = evaporating temperature

(*) Veuillez vous référer strictement aux Recommandations d'Utilisation et Bulletins Marketing Tecumseh du fait de la température de reflux élevée pour les applications LBP.

(*) Due to very high discharge temperature especially on LBP conditions, please strictly refer to Tecumseh Guidelines & Marketing Bulletin when using this refrigerant.

Nota : Tecumseh se réserve le droit de modifier les informations contenues dans ce document sans préavis.

Note : Tecumseh reserves the right to change information contained in this document without notification.